

Q16 Plunger Pump Data

198 BHP Continuous Duty (240 BHP Intermittent Duty)

Forged ISO Drawing

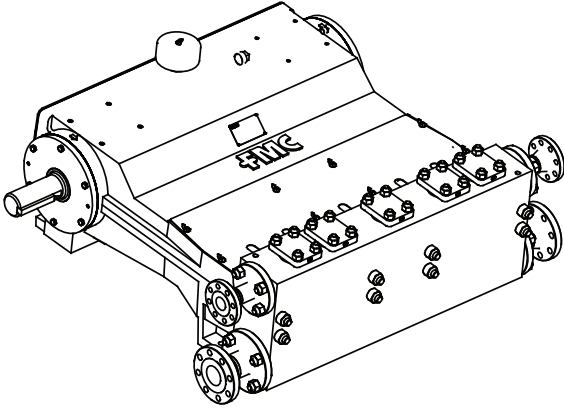

Cast ISO Drawing

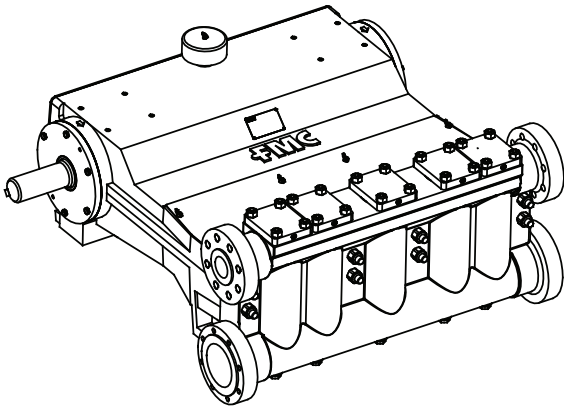

Specifications

Pump Model	Q16
Design Standard	API-674, Second Edition
Configuration	Horizontal Quintuplex Plunger
Number of Plungers	5
Stroke Length	4.0 Inches
Frame Load Rating	10,000 lbs
Forged Fluid Cylinder Pressure Rating	10,000 psi
Cast Fluid Cylinder Pressure Rating	3,000 psi
Pump Weight (Average)	4,500 lbs
Intermittent Duty Speed Rating	425 RPM
Continuous Duty Speed Rating	350 RPM
API-674 Max Recommended Speed	350 RPM
Minimum Speed *	100 RPM
Mechanical Efficiency	90%
Lubrication System (Standard)	Splash, Gravity Return
Lubrication System (Optional)	Pressurized, Motor or CrankDriven
Lube Oil Capacity	16 Gallons
Lube Oil Type	SAE 30
Maximum Fluid Temperature	200 °F (400 °F Capability)
Minimum Fluid Temperature	-20 °F (-50 °F Capability)
Valve Types	Disc Valves, Abrasion Resistant Valves

** Slower RPM can be achieved with the addition of a pressurized lubrication system*

Forged Fluid End Material	Cast Fluid End Material
A105 Carbon Steel	Ductile Iron
A350-LF2 Carbon Steel	Nickel Aluminum Bronze
316L Stainless Steel	316L Stainless Steel
2205 Duplex Stainless Steel	2205 Duplex Stainless Steel
Alloy Steel	

** Special Materials available on request*

Standard Connection Sizes	Suction	Discharge
Q1609-Q1618	4.0	2.0
Q1620-Q1628	6.0	3.0
Q1628-Q1636	8.0	4.0

** NPT Connections Available*

- Consult FMC for specific exceptions to API-674 and NACE standards.
- Consult FMC for any application where inlet pressures will exceed 10% of rated discharge pressure.
- Horsepower based on 90% mechanical efficiency. Actual application horsepower requirements can be calculated using the equation: $BHP = (GPM * PSI) / (1714 * 0.90)$
- Direction of rotation is the top of the crankshaft towards the fluid head.

Q16 Performance Table

Pump Model	Plunger Diameter (in)	Displacement (GAL/REV)	Pressure (PSI)	Pump Capacity (GPM) @ Input Speed (RPM)					
				100 RPM	200RPM	300RPM	350RPM	400RPM	425RPM
Q1609	1.125	0.0861	10,000	8.6	17	26	30	34	37
Q1610	1.250	0.1062	8,150	11	21	32	37	43	45
Q1612	1.500	0.1530	5,650	15	31	46	54	61	65
Q1614	1.750	0.2082	4,160	21	42	63	73	83	89
Q1616	2.000	0.2720	3,190	27	54	82	95	109	116
Q1618	2.250	0.3442	2,520	34	69	103	121	138	146
Q1620	2.500	0.4250	2,040	43	85	128	149	170	181
Q1622	2.750	0.5142	1,690	51	103	154	180	206	219
Q1624	3.000	0.6120	1,420	61	122	184	214	245	260
Q1626	3.250	0.7182	1,210	72	144	216	251	287	305
Q1628	3.500	0.8330	1,040	83	167	250	292	333	354
Q1630	3.750	0.9562	910	96	191	287	335	383	406
Q1632	4.000	1.0880	800	109	218	326	381	435	462
Q1634	4.250	1.2282	710	123	246	369	430	491	522
Q1636	4.500	1.3770	630	138	275	413	482	551	585

Q16 NPSHr values for Disc Valves with 2-springs

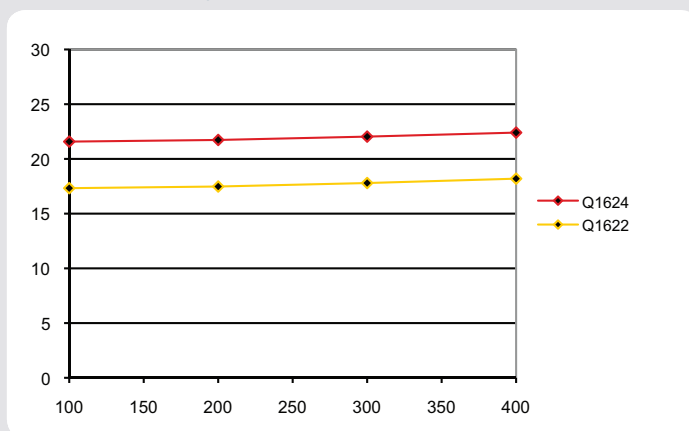

- Pump capacities shown are based on 100% volumetric efficiency.
- FMC recommends NPSHa (available) exceeds NPSHr (required) by 5 feet of water.
- Take special consideration when calculating NPSHa. Recalculate NPSHa after pump model has been selected for more accurate values.
- NPSHr values are in feet of water. If you are pumping a different liquid than water, convert the required NPSH from water to the liquid being pumped by dividing the published NPSHr value by the specific gravity of the liquid being pumped.
- FMC published NPSHr values are based on test data collected on specific pumps at the factory and are estimated values. Actual NPSHr values for an ordered pump can only be determined by a factor test. For NPSH critical applications, contact the factory for additional information and request an NPSHr test performed on your pump before shipment.

Q16 Plunger Pump Data

198 BHP Continuous Duty (240 BHP Intermittent Duty)

Forged Pump Engineering Dimensional Outline

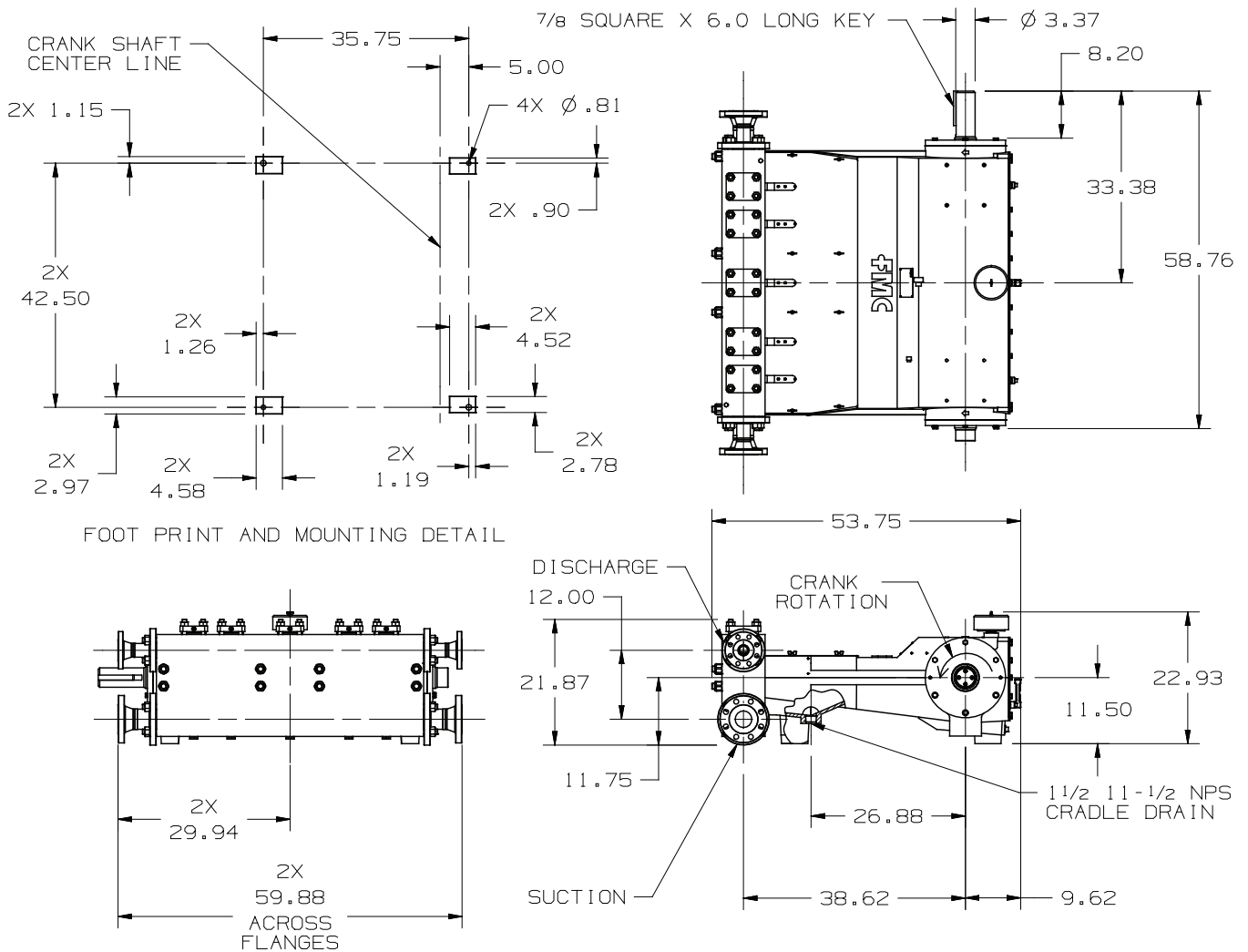

Q16 Plunger Pump Data

198 BHP Continuous Duty (240 BHP Intermittent Duty)

Cast Pump Engineering Dimensional Outline

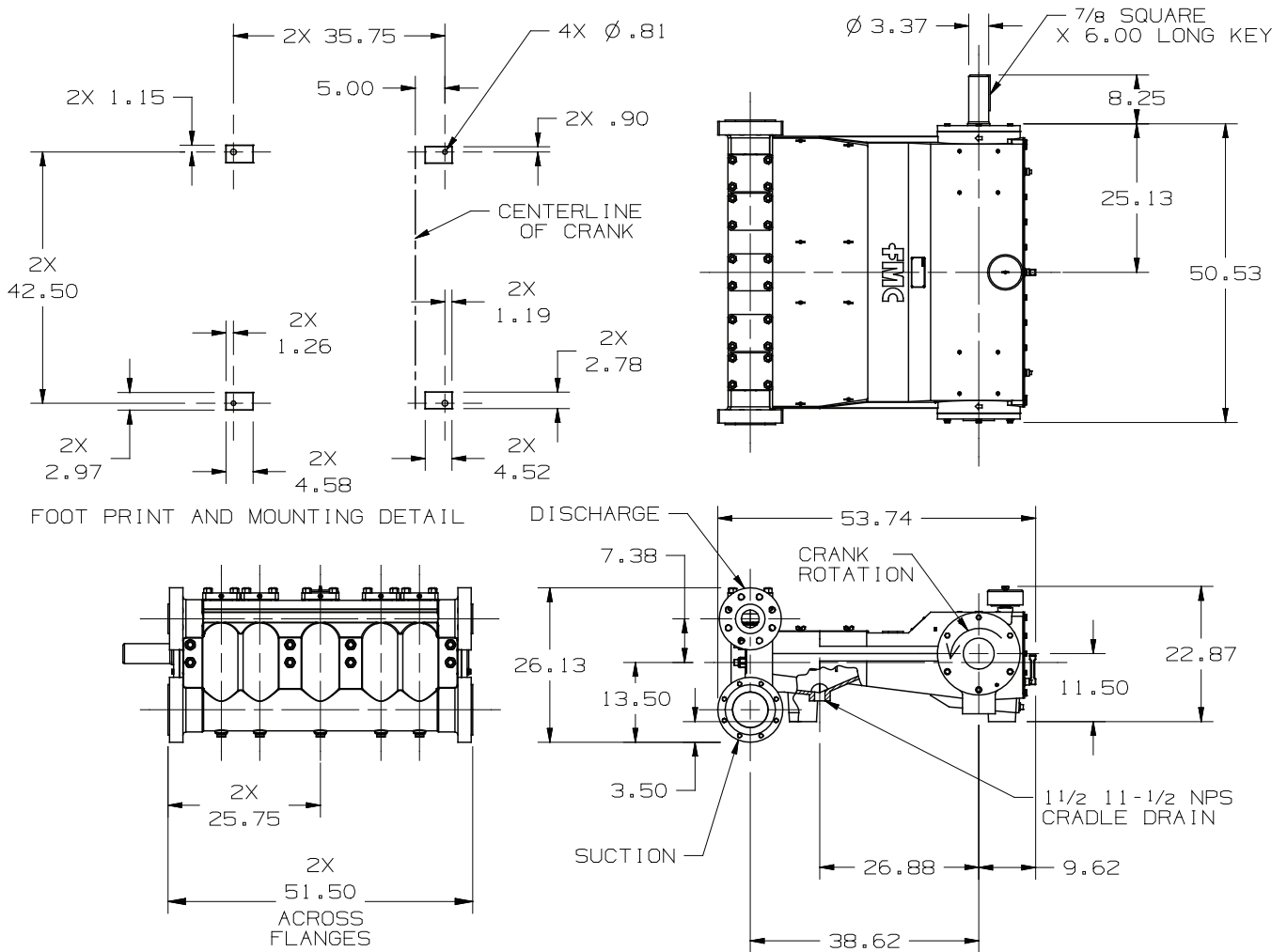

• Dimensions shown are for general sizing purposes and should not be used of construction. Contact FMC for actual dimensions of pump ordered.

• FMC reserves the right to modify this information without prior notice.

• Pump drawing dimensions in inches.