

M28 Plunger Pump Data

350 BHP Continuous Duty (440 BHP Intermittent Duty)

Forged ISO Drawing

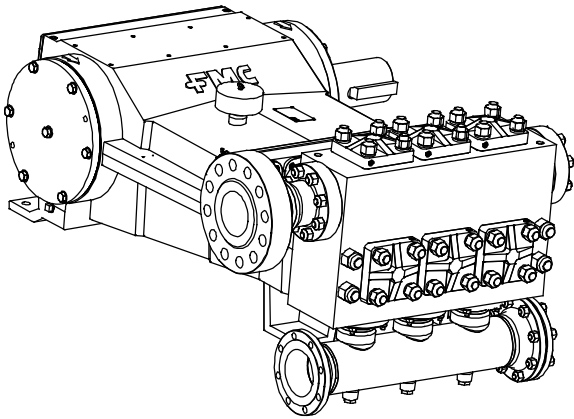

Specifications

Pump Model	M28
Design Standard	API-674, Second Edition
Configuration	Horizontal Triplex Plunger
Number of Plungers	3
Stroke Length	7.0 Inches
Frame Load Rating	25,000 lbs
Forged Fluid Cylinder Pressure Rating	10,000 psi
Cast Fluid Cylinder Pressure Rating	Not Available
Pump Weight (Average)	5,500 lbs
Intermittent Duty Speed Rating	300 RPM
Continuous Duty Speed Rating	240 RPM
API-674 Max Recommended Speed	240 RPM
Minimum Speed *	100 RPM
Mechanical Efficiency	90%
Lubrication System (Standard)	Splash, Gravity Return
Lubrication System (Optional)	Pressurized, Motor or Crank Driven
Lube Oil Capacity	13.75 Gallons
Lube Oil Type	SAE 30
Maximum Fluid Temperature	200 °F (400 °F Capability)
Minimum Fluid Temperature	-20 °F (-50 °F Capability)
Valve Types	Disc Valves, Abrasion Resistant Valves

* Slower RPM can be achieved with the addition of a pressurized lubrication system

Forged Fluid End Material	
A105 Carbon Steel	
A350-LF2 Carbon Steel	
316L Stainless Steel	
2205 Duplex Stainless Steel	
Alloy Steel	

* Special Materials available on request

Standard Connection Sizes	Suction	Discharge
M2812-M2820	4.0	2.0
M2822-M2832	6.0	3.0
M2834-M2842	8.0	4.0
M2844-M2850	10.0	4.0

* NPT Connections Available

- Consult FMC for specific exceptions to API-674 and NACE standards.
- Consult FMC for any application where inlet pressures will exceed 10% of rated discharge pressure.
- Horsepower based on 90% mechanical efficiency. Actual application horsepower requirements can be calculated using the equation: $BHP = (GPM * PSI) / (1714 * 0.90)$
- Direction of rotation is the top of the crankshaft towards the fluid head.

Customer Service
 (800) 772-8582
 2825 W. Washington St.
 Stephenville, TX 76401
 www.FMCPumps.com

M28 Performance Table

Pump Model	Plunger Diameter (in)	Displacement (GAL/REV)	Pressure (PSI)	Pump Capacity (GPM) @ Input Speed (RPM)					
				100 RPM	150RPM	200RPM	240RPM	250RPM	300RPM
M2812	1.500	0.1606	10,000	16	24	32	39	40	48
M2814	1.750	0.2187	10,000	22	33	44	53	55	66
M2816	2.000	0.2856	7,960	29	43	57	69	71	86
M2818	2.250	0.3615	6,300	36	54	72	87	90	109
M2820	2.500	0.4462	5,100	45	67	89	107	112	134
M2822	2.750	0.5400	4,200	54	81	108	130	135	162
M2824	3.000	0.6426	3,540	64	96	129	154	161	193
M2826	3.250	0.7542	3,015	75	113	151	181	189	226
M2828	3.500	0.8746	2,600	88	131	175	210	219	262
M2830	3.750	1.0041	2,260	100	151	201	241	251	301
M2832	4.000	1.1424	1,990	114	171	229	274	286	343
M2834	4.250	1.2897	1,760	129	194	258	310	322	387
M2836	4.500	1.4458	1,570	145	217	289	347	361	434
M2838	4.750	1.6110	1,400	161	242	322	387	403	483
M2840	5.000	1.7580	1,275	176	264	352	422	440	527
M2842	5.250	1.9680	1,155	197	295	394	472	492	590
M2844	5.500	2.1598	1,050	216	324	432	518	540	648
M2846	5.750	2.3607	960	236	354	472	567	590	708
M2848	6.000	2.5704	880	257	386	514	617	643	771
M2850	6.250	2.7891	815	279	418	558	669	697	837

M28 NPSHr values for Disc Valves with 2-springs

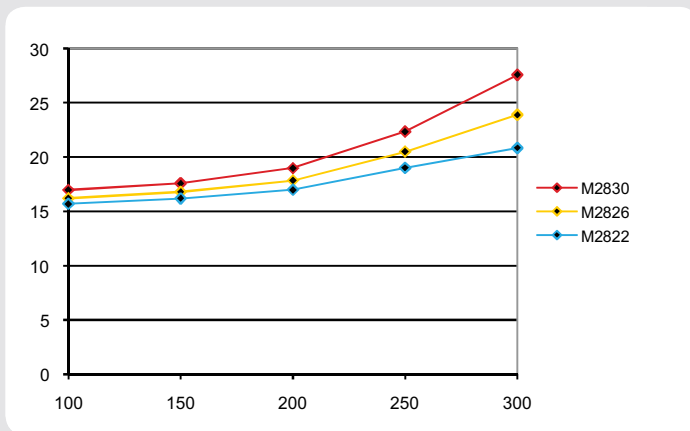

FMC Bolt-on Gearbox Ratios Available
6.17 : 1
7.44 : 1
9.58 : 1

- Pump capacities shown are based on 100% volumetric efficiency.
- FMC recommends NPSHa (available) exceeds NPSHr (required) by 5 feet of water.
- Take special consideration when calculating NPSHa. Recalculate NPSHa after pump model has been selected for more accurate values.
- NPSHr values are in feet of water. If you are pumping a different liquid than water, convert the required NPSH from water to the liquid being pumped by dividing the published NPSHr value by the specific gravity of the liquid being pumped.
- FMC published NPSHr values are based on test data collected on specific pumps at the factory and are estimated values. Actual NPSHr values for an ordered pump can only be determined by a factor test. For NPSH critical applications, contact the factory for additional information and request an NPSHr test performed on your pump before shipment.

M28 Plunger Pump Data

350 BHP Continuous Duty (440 BHP Intermittent Duty)

Forged Pump Engineering Dimensional Outline

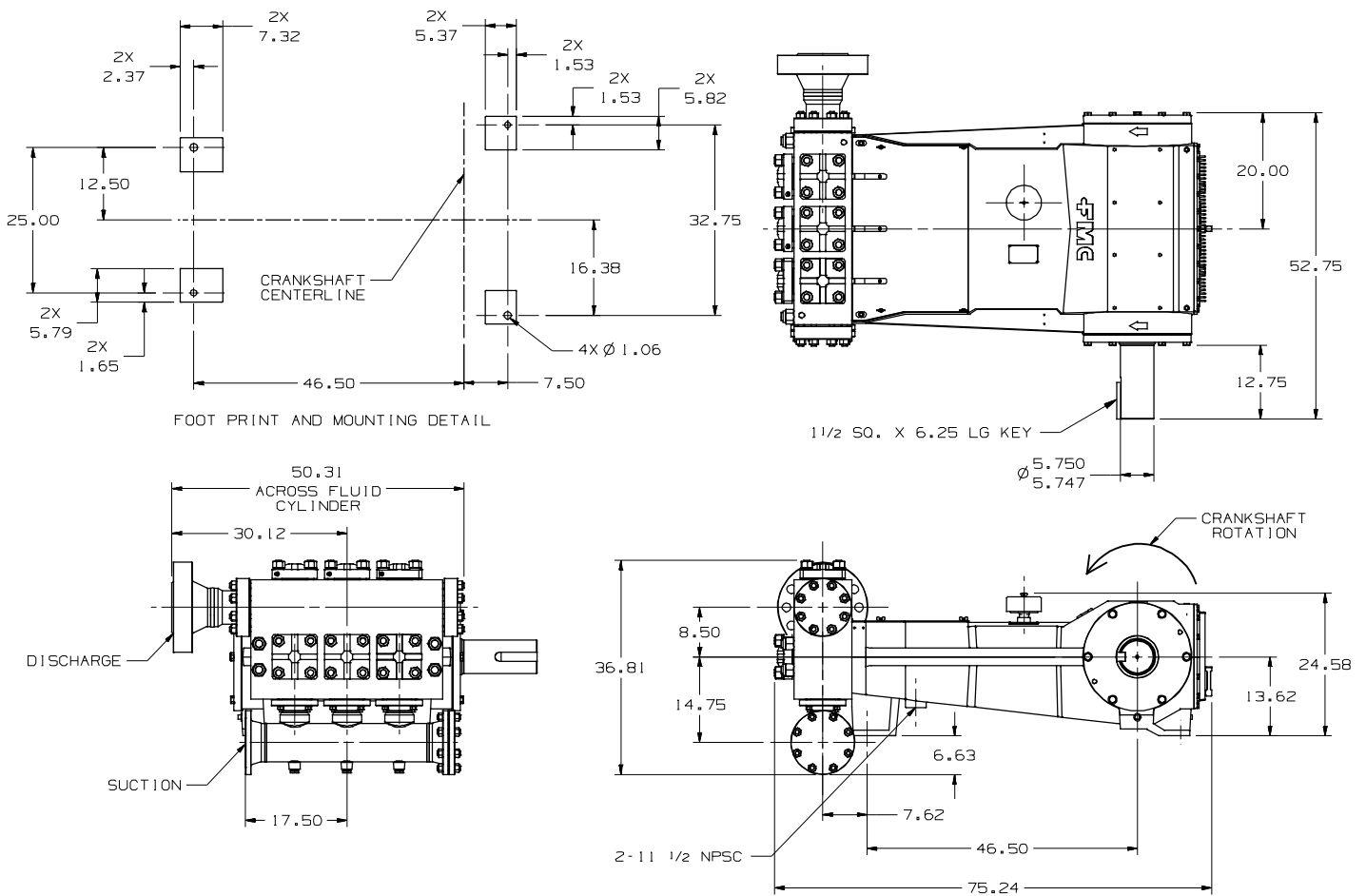

Customer Service
 (800) 772-8582
 2825 W. Washington St.
 Stephenville, TX 76401
 www.FMCPumps.com

M28 Plunger Pump Data

350 BHP Continuous Duty (440 BHP Intermittent Duty)

M28 Forged Pump with Gearbox Engineering Dimensional Outline

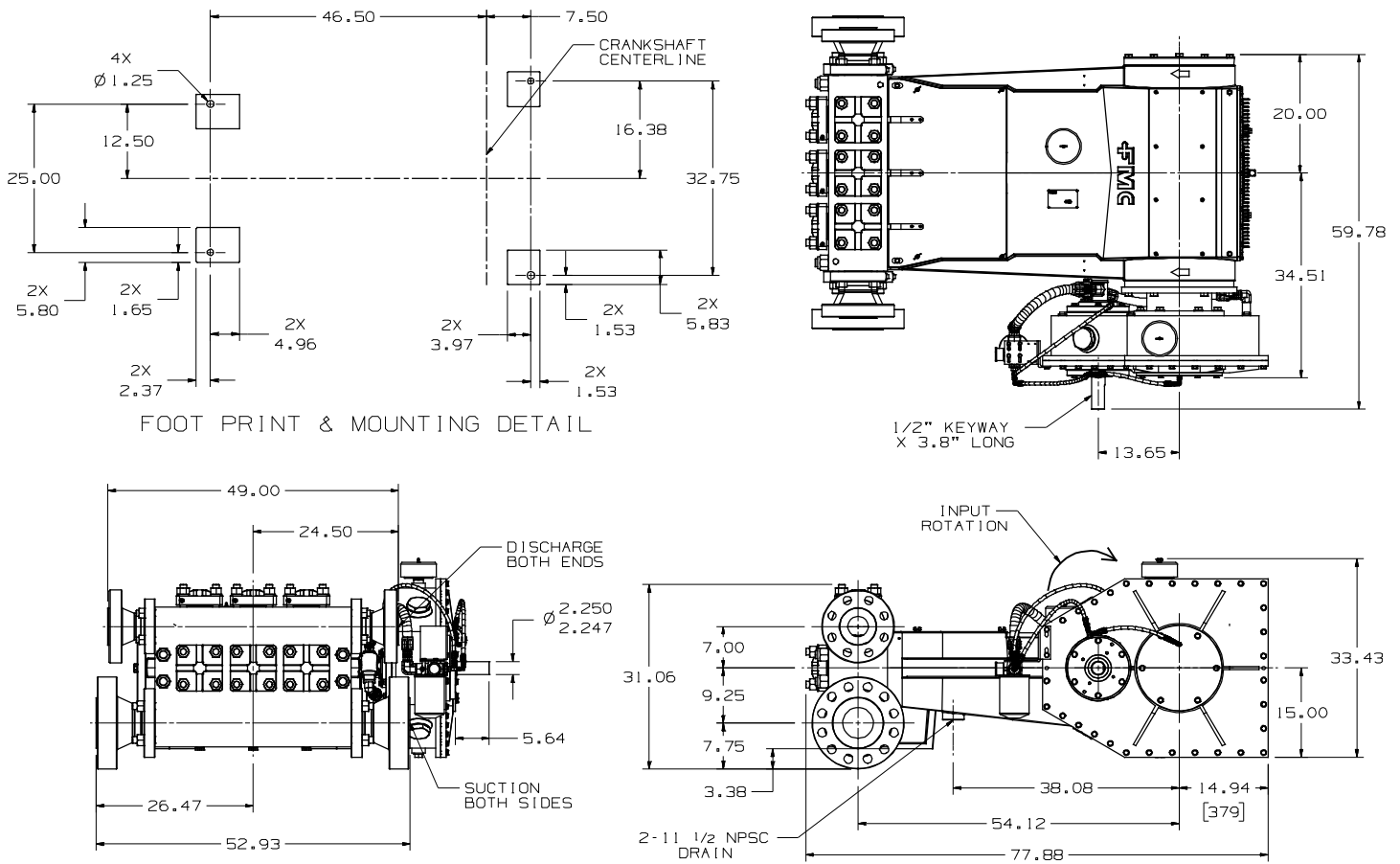

• Dimensions shown are for general sizing purposes and should not be used of construction. Contact FMC for actual dimensions of pump ordered.

• FMC reserves the right to modify this information without prior notice.

• Pump drawing dimensions in inches.